

Cycle counters positively monitor mold activity, validate process monitoring data and assist mold maintenance procedures

Product Code	L	B	D	H
Z5260	50	38	24.5	7.5

Product Code	B	A	L	L1	L2	R	S
Z5263	38	26	48	24	28	8	Min 3.5

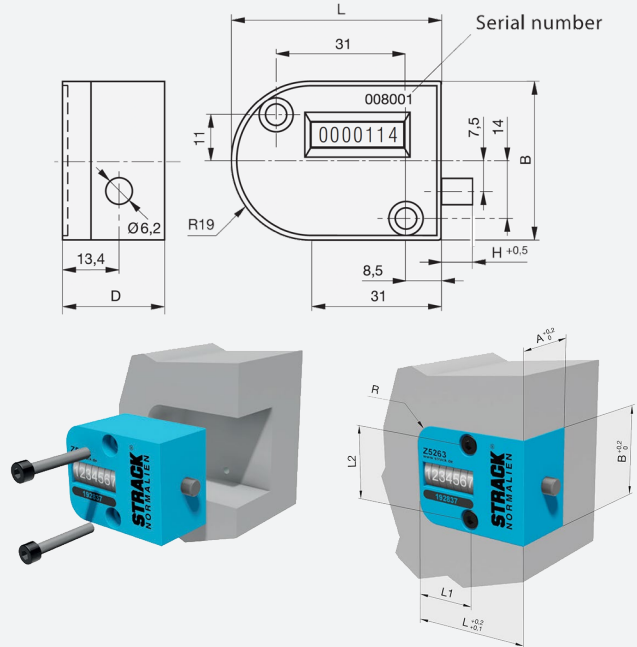

This unit contains an electronic circuit which counts the number of cycles made & checks the exact total life time of the mould. To determine how many shots a mould made when out sourced. Predicts preventive maintenance. Available with partial reset. The unique part number for each counter gives a guarantee and a planning aid to the moulder. Any tampering is shown in the screen.

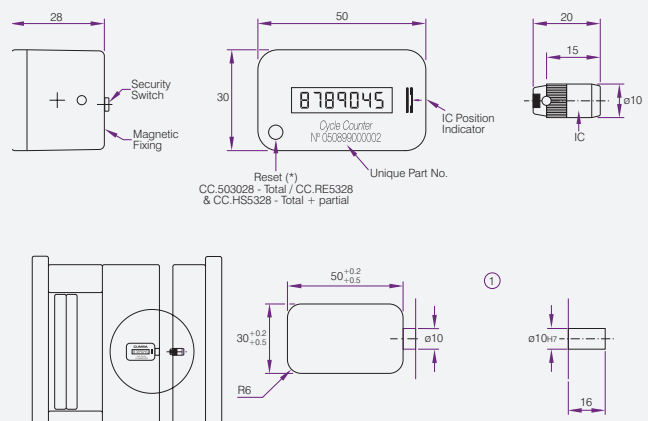

Product Code	Cycles/min	Battery
CC.HS5328	Up to 500	ER 14250 ½ AA