

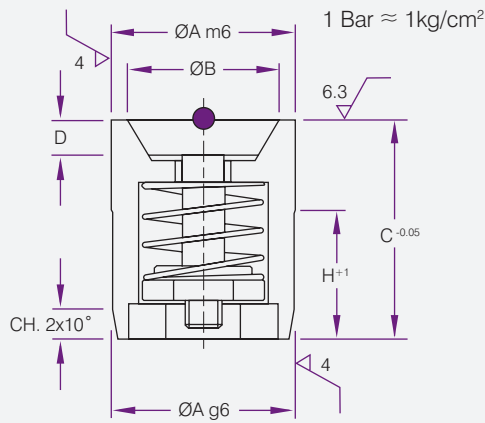

VA

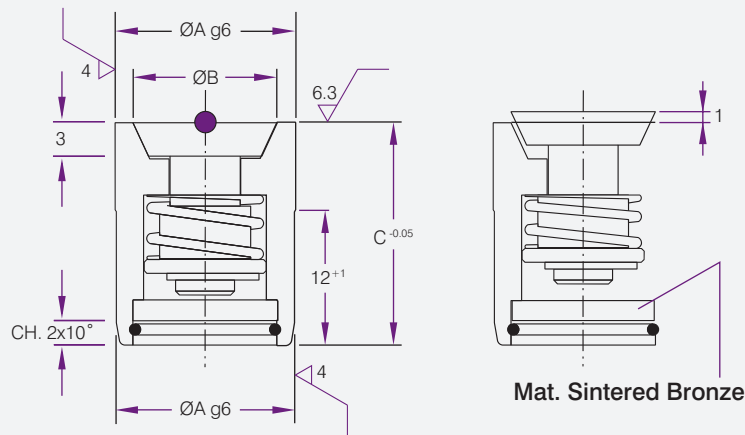

FV



Mat.: INOX. 1.4034
 Hardened 51 ± 3 HRC.
 Working pressure 1.5-6 BARS.

Helps part ejection with air. FV has a filter incorporated. VD Allows venting. Wide range of diameters. Offers a standard solution to the moulder.

Standard Air Poppets

Ref.	A	B	C	D	E	H
VA.050412	5	3	12	1.5	4	7
VA.065212	6	5.2	12	1.5	4	7
VA.086512	8	6.5	12	1.5	4	7
VA.100812	10	8	12	2	8	7
VA.121012	12	10	12	2.5	10	7
VA.161320	16	13	20	3	12	12
VA.201720	20	17	20	3.5	16	12

Filter Valve

Product Code	A	B	C	E
FV.161320	16	13	20	14
FV.201720	20	17	20	18