

STRACK
NORMALIEN

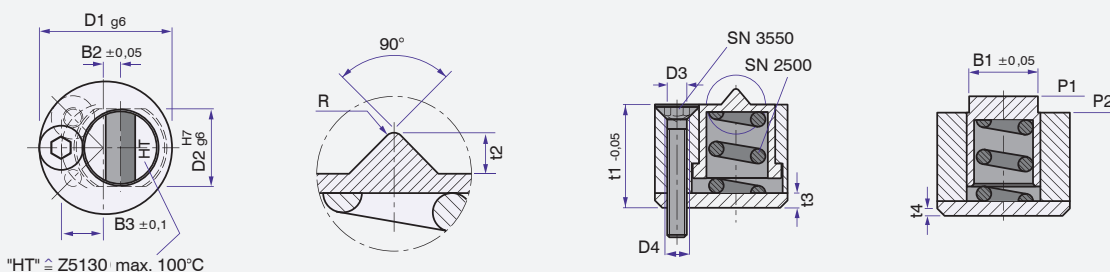

Mat. -Nr. 1.2842/58 + 2HRC

Order: Z5130 - D1

D1	B1	B2	B3	t1	t2	t3	t4	D2	D3	D4	R	P1(N)	P2(N)	SN 2500	SN3550
13	6,6	1,4	4,3	10	1,0	1,6	0,35	7	2,2	M3	0,35	28	34	5-12	M2-16
18	9,6	2,0	6,0	14	1,8	2,0	0,50	10	3,2	M4	0,5	38	42	8-16,5	M3-20
27	14,4	3,0	9,0	21	2,8	3,0	0,50	15	4,3	M5	0,75	38	92	11,6-18,5	M4-25

STRACK
NORMALIEN

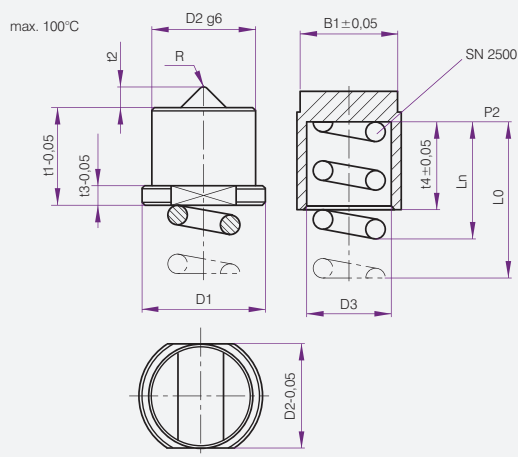

Mat. -Nr 1.2842/58 ± 2HRC

Order: Z5134 - D1

D2	B1	t1	t2	t3	t4	D1	D3	R	L0	Ln	P2(N)	SN2500-
7	6,6	7	1,0	1,4	6,3	8,4	5,3	0,35	12	7,5	34	5-12
10	9,6	10	1,8	2,0	9,0	12,0	8,3	0,50	16	10,0	42	8-16,5
15	14,4	15	2,8	3,0	13,5	18,0	12,4	0,75	18	16,0	92	11,6-18,5