

IMPORTANT
K = Approximate resistance value that can be obtained by grouping clips

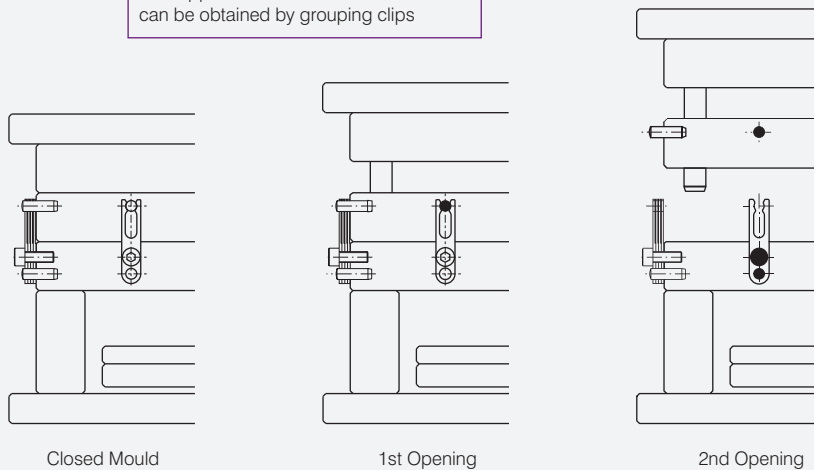

Mat.: 1.8159
Hardened 45 ± 3HRC
Patented System

No pocket machining required as needed with other similar products on the market. Minimum space required for installation. Reduces costs compared to conventional mechanisms. Offers a standard solution to the moulder.

Product Code	K
RM.651608	7.5kg